

ASSEMBLY INSTRUCTIONS

SKU: HMATG63S



175 Southbelt Industrial Dr
Houston, TX 77047

Email: info@eastwestfurniture.net

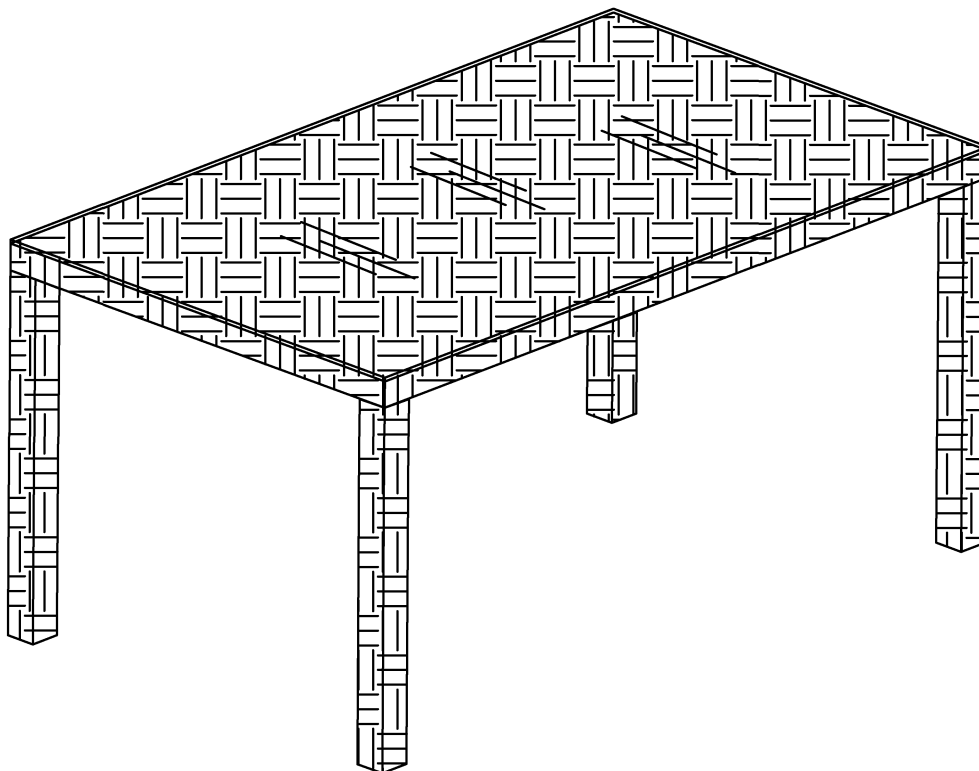

Description : Madrid table with glass top, wicker F2425S
Dimension : L150xW90xH75cm
Cube Size :

NW : 30 KGS
GW : 34 KGS

BEFORE ASSEMBLY

Thank you for purchasing this quality product. This product has been designed for easy assembly and constructed for durability. Please take the time to read and follow the assembly instructions carefully.

Be sure to check all packing material carefully for small parts which may have come loose inside the carton during shipment. Please separate, identify, and count all parts and metal hardware. Compare with part list to be sure all parts are present.

If hardware is missing or you have difficulty assembling this product, please call for us.

IMPORTANT NOTE:

- Place all wooden parts on a clean and smooth surface such as a rug or carpet to avoid the parts from being scratched.
- Remove all wrapping material, including staples & packing straps before you start to assemble.
- DO NOT tighten all screws and bolts until completely assembled.
- Keep all hardware parts out of reach of children.

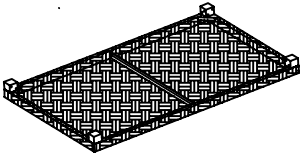
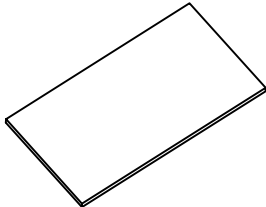

PART LIST

When unpacking, please be careful not to discard any parts with the packaging. Before continuing, please make sure you have the following parts:

Part List:	Description	Qty		NO	Description	Qty	
A	Table legs	4					
B	Table Top	1					
C	Glass Panel	1					

HARDWARE LIST

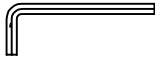
When unpacking, please be careful not to discard any parts with the packaging. Before continuing, please make sure you have all of the following hardware:

NO	Description	Qty	Sketch	NO	Description	Qty	Sketch
1	Botl (M6x20)	8		3	Allen key (M4mm)	1	
2	Washer	8					

STEP 1

With the table top (B) flipped upside down, attach four table legs (A) to 4 corners of the table top (B) with bolts (1) and washer (2) then tighten with the Allen Key as shown on the picture below:

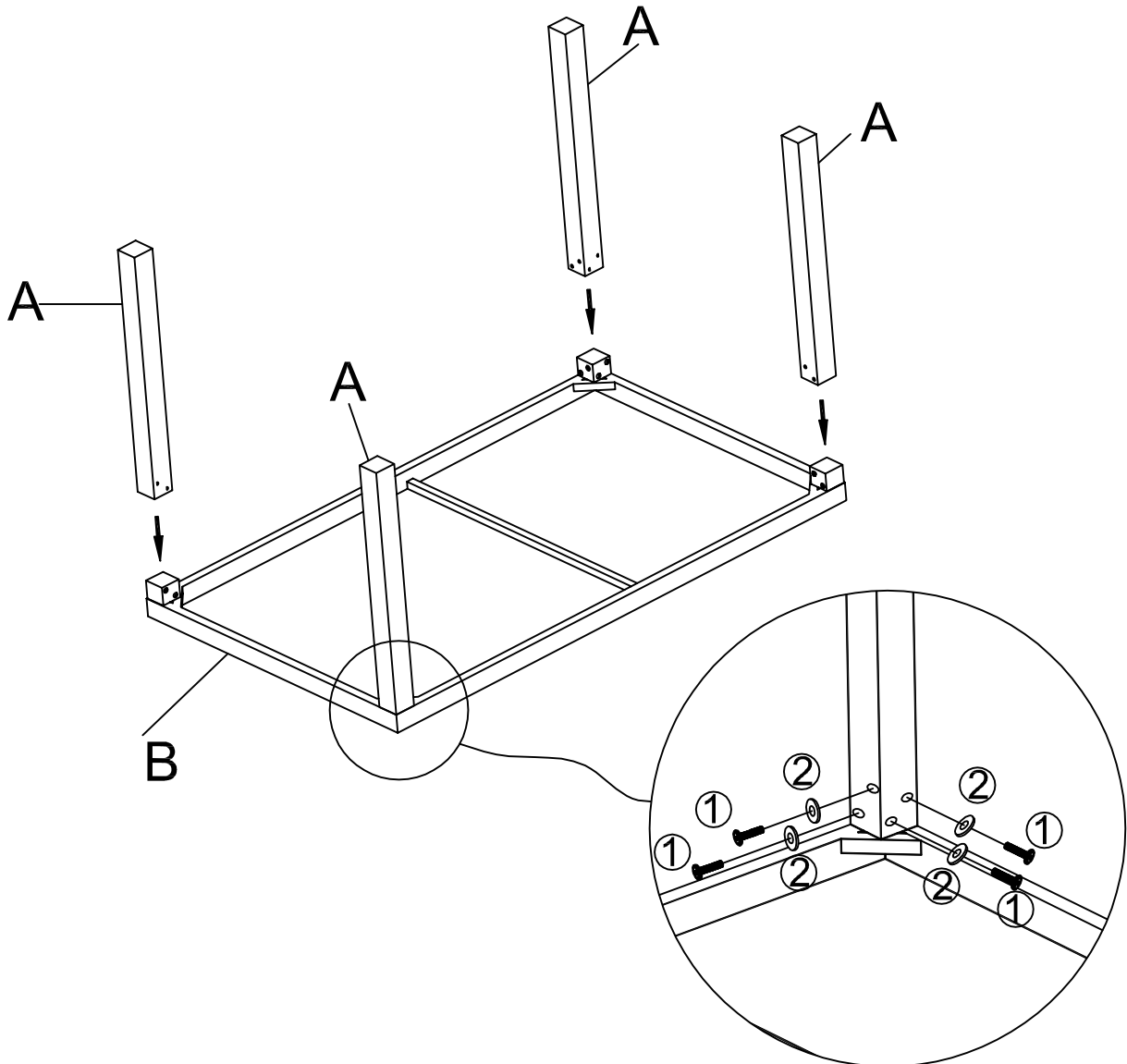

STEP 2

Gently place the glass panel (C) onto the table top

