

# ASSEMBLY INSTRUCTIONS

SKU: BCMCWNA



175 Southbelt Industrial Dr  
Houston, TX 77047

Email: [info@eastwestfurniture.net](mailto:info@eastwestfurniture.net)

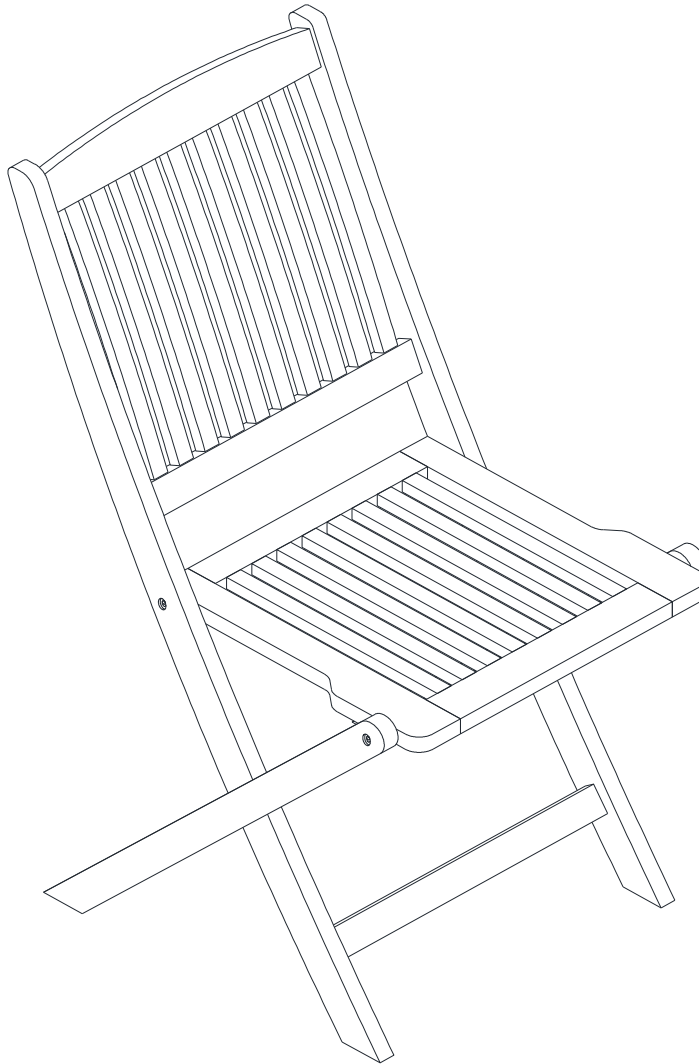

*Description* : Cameron Chair Wood Seat

*Dimension* : 18.5"Wx23.4"Dx35.4H

*Cube Size* : 44.3"x20.7"x8.5"

NW: 18.5 LBS

GW: 25 LBS

**Cameron Chair Wood Seat**

## BEFORE ASSEMBLY

Thank you for purchasing this quality product. This product has been designed for easy assembly and constructed for durability. Please take the time to read and follow the assembly instructions carefully.

Be sure to check all packing material carefully for small parts which may have come loose inside the carton during shipment. Please separate, identify, and count all parts and metal hardware. Compare with part list to be sure all parts are present. If hardware is missing or you have difficulty assembling this product, please call for us.

**IMPORTANT NOTE:**

- Place all wooden parts on a clean and smooth surface such as a rug or carpet to avoid the parts from being scratched.
- Remove all wrapping material, including staples & packing straps before you start to assemble.
- DO NOT tighten all screws and bolts until completely assembled.
- Keep all hardware parts out of reach of children.



## PART LIST

When unpacking, please be careful not to discard any parts with the packaging. Before continuing, please make sure you have the following parts:

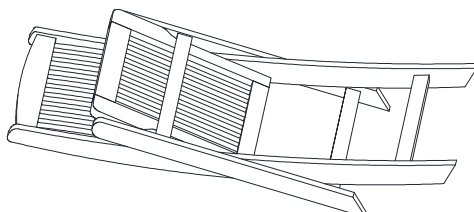
NO	Description	Qty	Sketch
A	Chair	1	

## STEP 1

Open the chair follow direction of arrows as shown below.

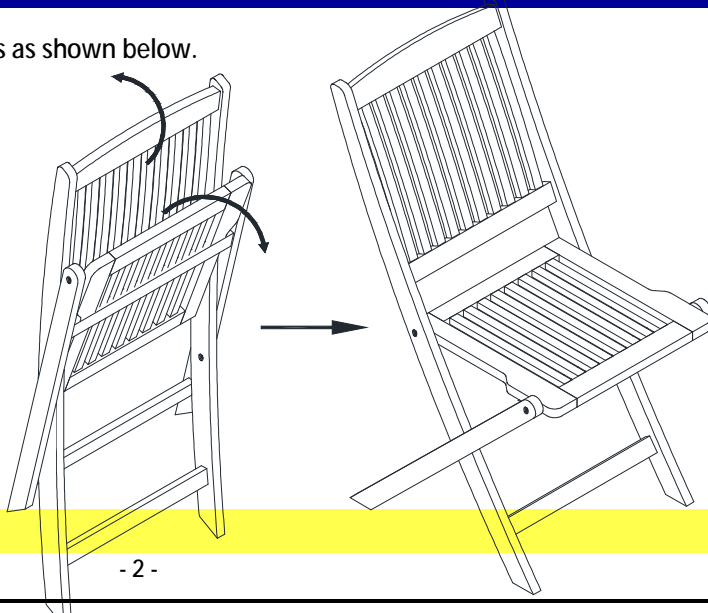

**Cameron Chair Wood Seat**

