

ASSEMBLY INSTRUCTIONS

SKU:UPK



175 Southbelt Industrial Dr,
Houston, TX 77047

Email:sales@eastwestfurniture.net

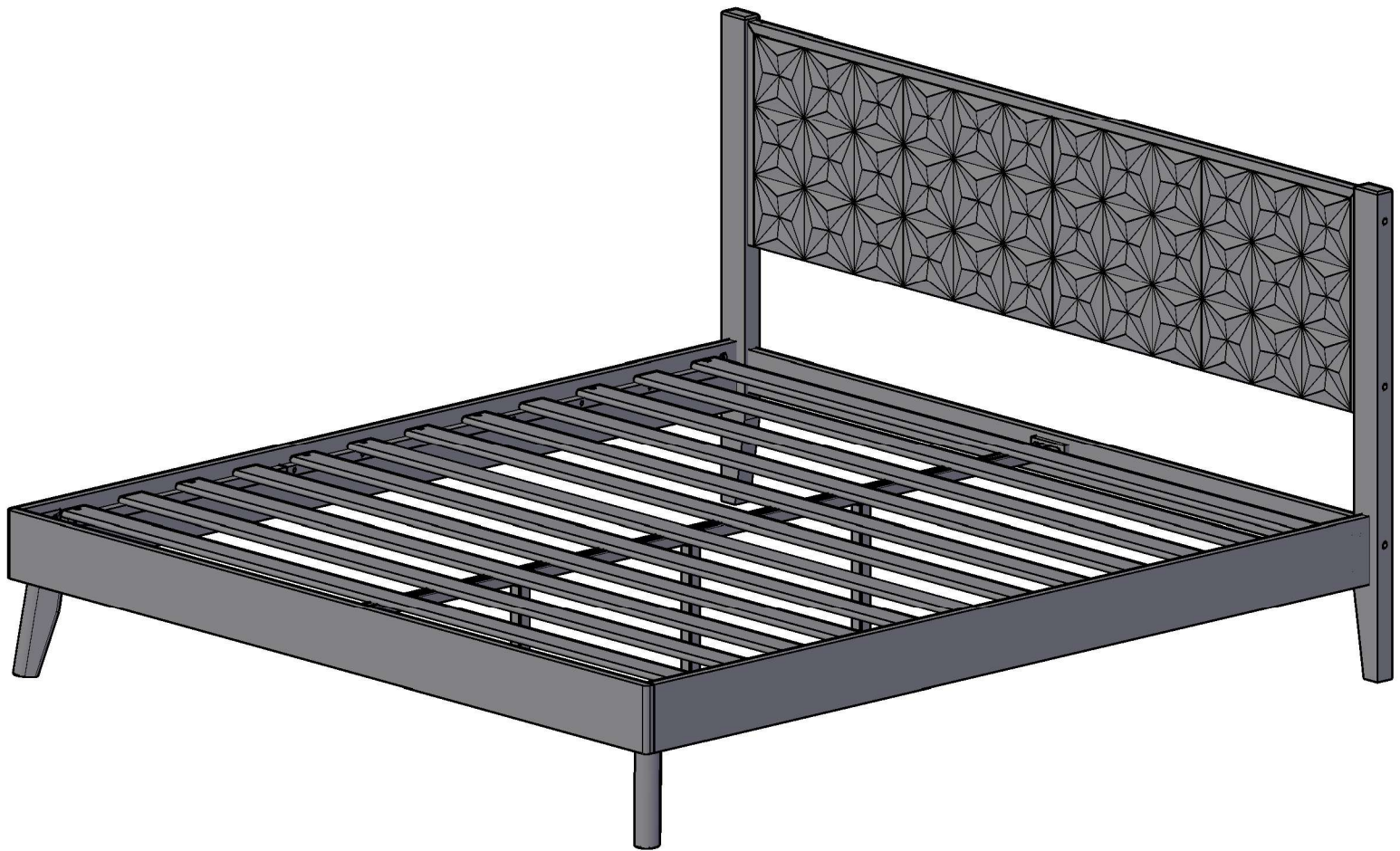

Description : UPLAND KING BED
Product Dimension : 80.1"Wx83"Lx42"H
Cube Size : 84.5"x22"x6.3"

NW : 101.2 LBS
GW : 110 LBS

BEFORE ASSEMBLY





Thank you for purchasing this quality product. This product has been designed for easy assembly and constructed for durability. Please take the time to read and follow the assembly instructions carefully.

Be sure to check all packing material carefully for small parts which may have come loose inside the carton during shipment. Please separate, identify, and count all parts and metal hardware. Compare with part list to be sure all parts are present.

If hardware is missing or you have difficulty assembling this product, please contact us at sales@eastwestfurniture.net.

IMPORTANT NOTE:

- Place all wooden parts on a clean and smooth surface such as a rug or carpet to avoid the parts from being scratched.
- Remove all wrapping material, including staples & packing straps before you start to assemble.
- DO NOT TIGHTEN all screws and bolts until product is completely assembled.
- Keep all hardware parts out of reach of children.

Estimated time for assembly	People recommended for assembly	Tools Needed	Use power tools with caution
 Allow 60 minutes.	 2 People Build Make it a team effort! Grab a friend for quicker, easier assembly.	 Grab a Phillips head screwdriver to conquer this assembly.	 Use power tools with caution.

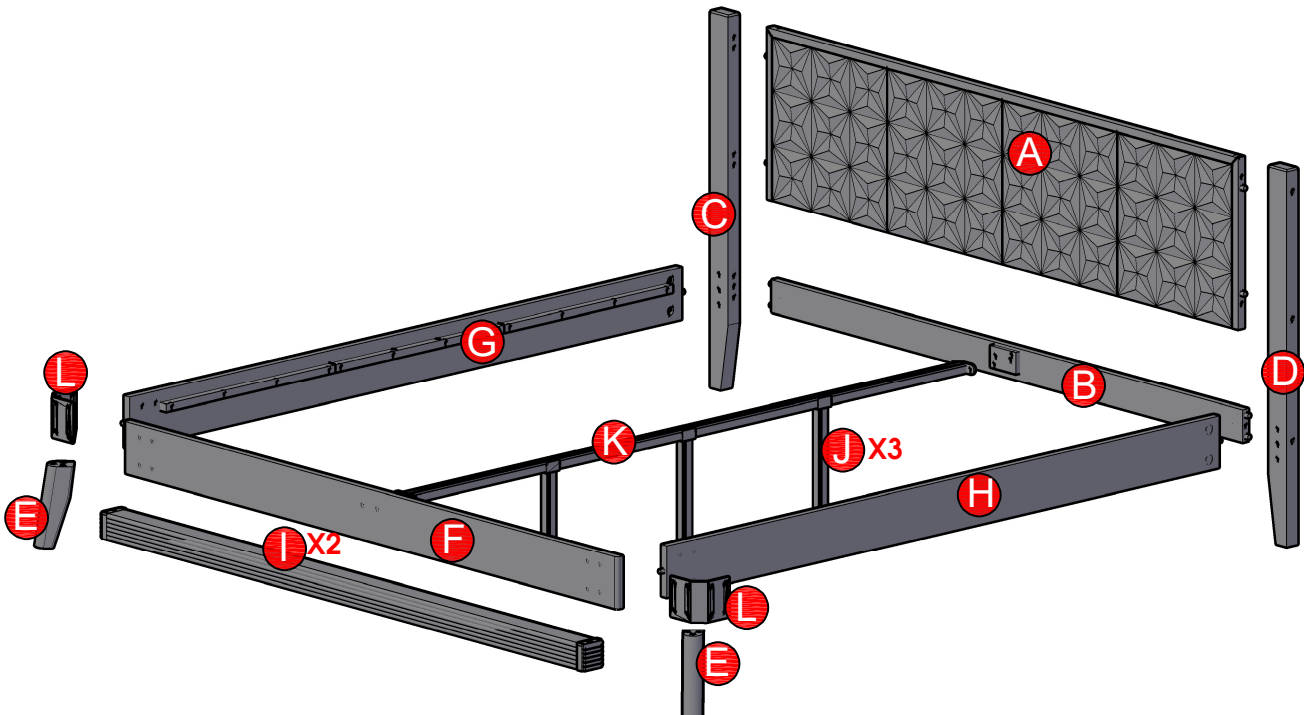

PART LIST

- When unpacking, please be careful not to discard any parts with the packaging. Before continuing, please make sure you have the following parts.

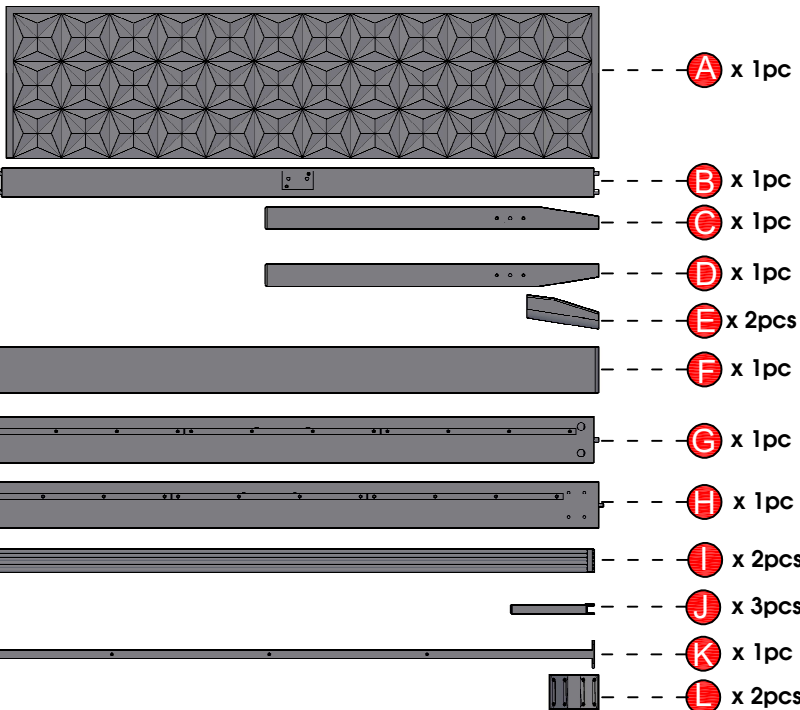

HARDWARE LIST

- When unpacking, please be careful not to discard any parts with the packaging. Before continuing, please make sure you have all of the following hardware:

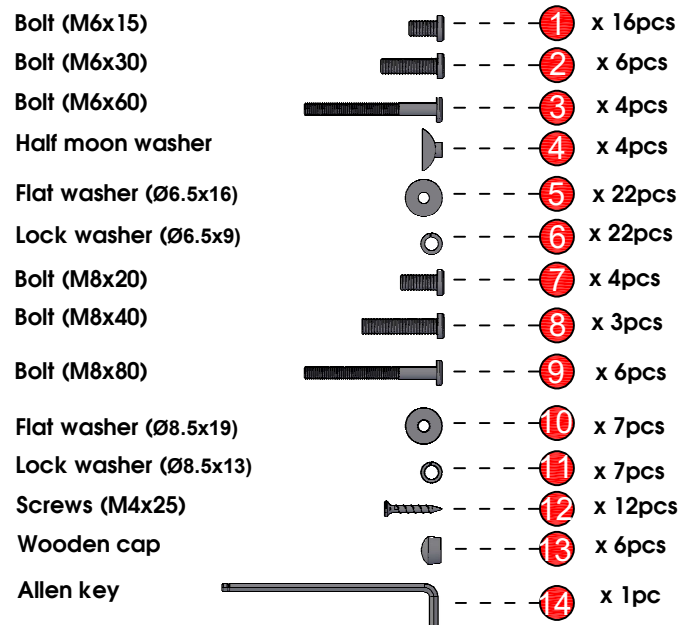

STEP 1

- Attach Headboard legs (C) & (D) to Headboard stretcher (B) using Bolts (9).
- Tighten with Allen key (14).

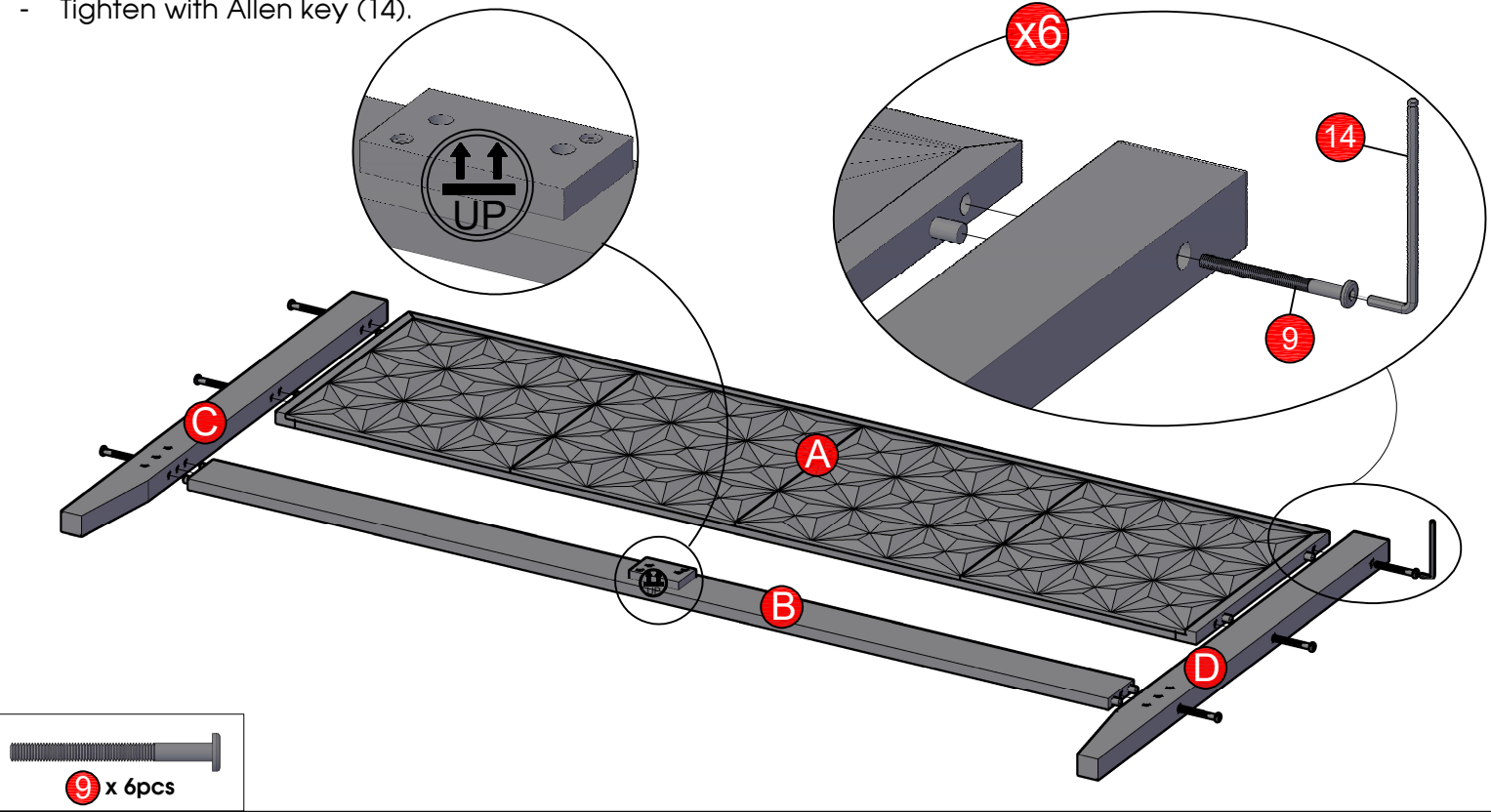

STEP 2

- Attach leg (E) to supporting bracket (L) using bolts (2), Flat Washers (5) and Lock Washer (6).
- Attach supporting bracket (L) to footboard (F) using bolts (1), Flat Washers (5) and Lock Washer (6).
- Tighten with Allen key (14).

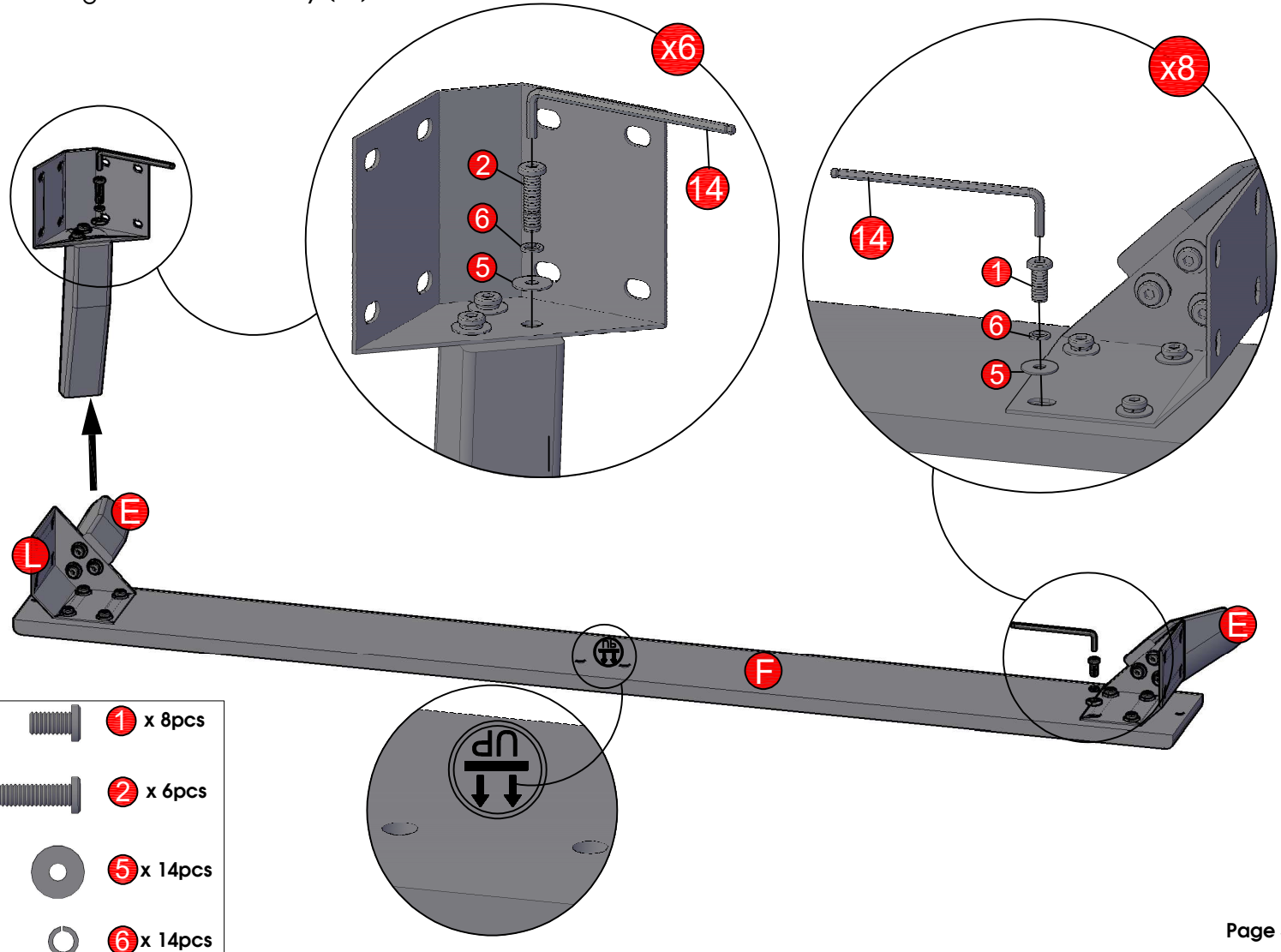

STEP 3

- Find some blocks or anything you have available to prop up Side Rails (H) & (G) while attaching them to the Headboard.
- Attach Side rails (H)&(G) to the Headboard leg (from step 1) using Bolts (3), Half moon washer(4).
- Tighten with Allen Key (14).

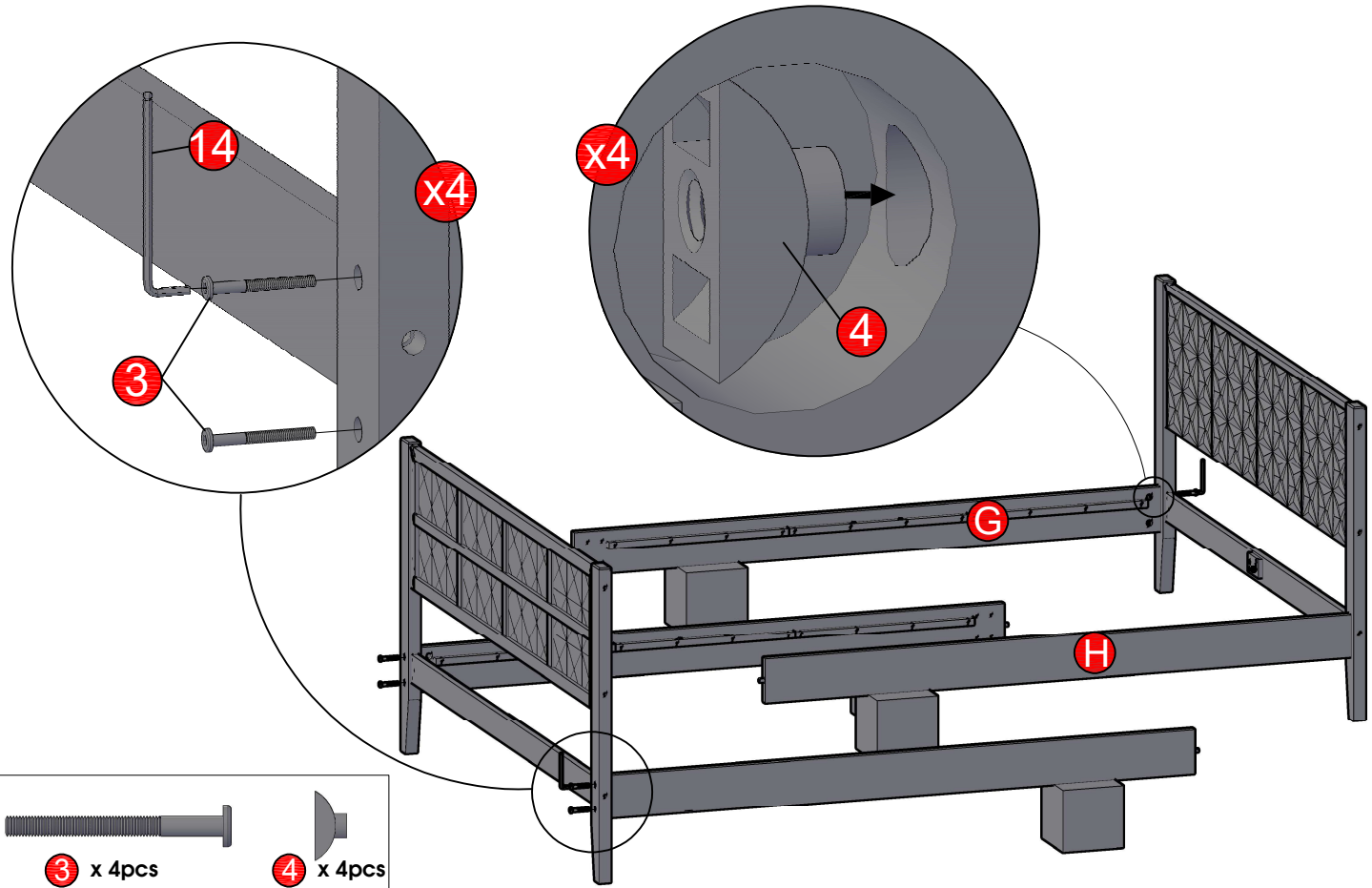

STEP 4

- Attach Side rails (from step 3) to the footboard legs (from step 2) using bolts (1), Flat Washers (5) and Lock Washer (6).
- Tighten with Allen key (14).

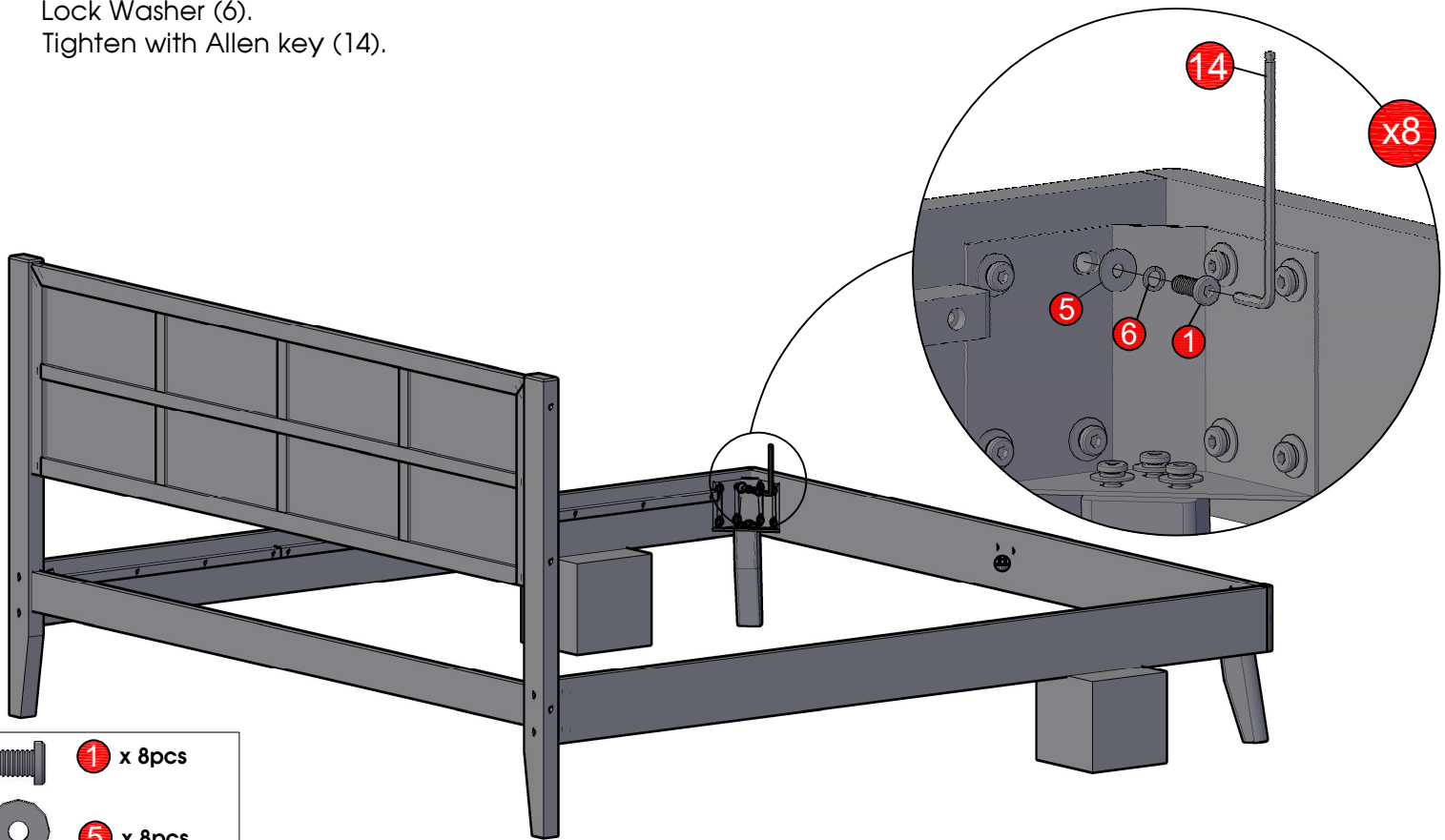

STEP 5

- Attach Support legs (J) to Centre rail (K) using Bolts (8), Flat washers (10) and Lock washers (11).
- Tighten with Allen Key (14).

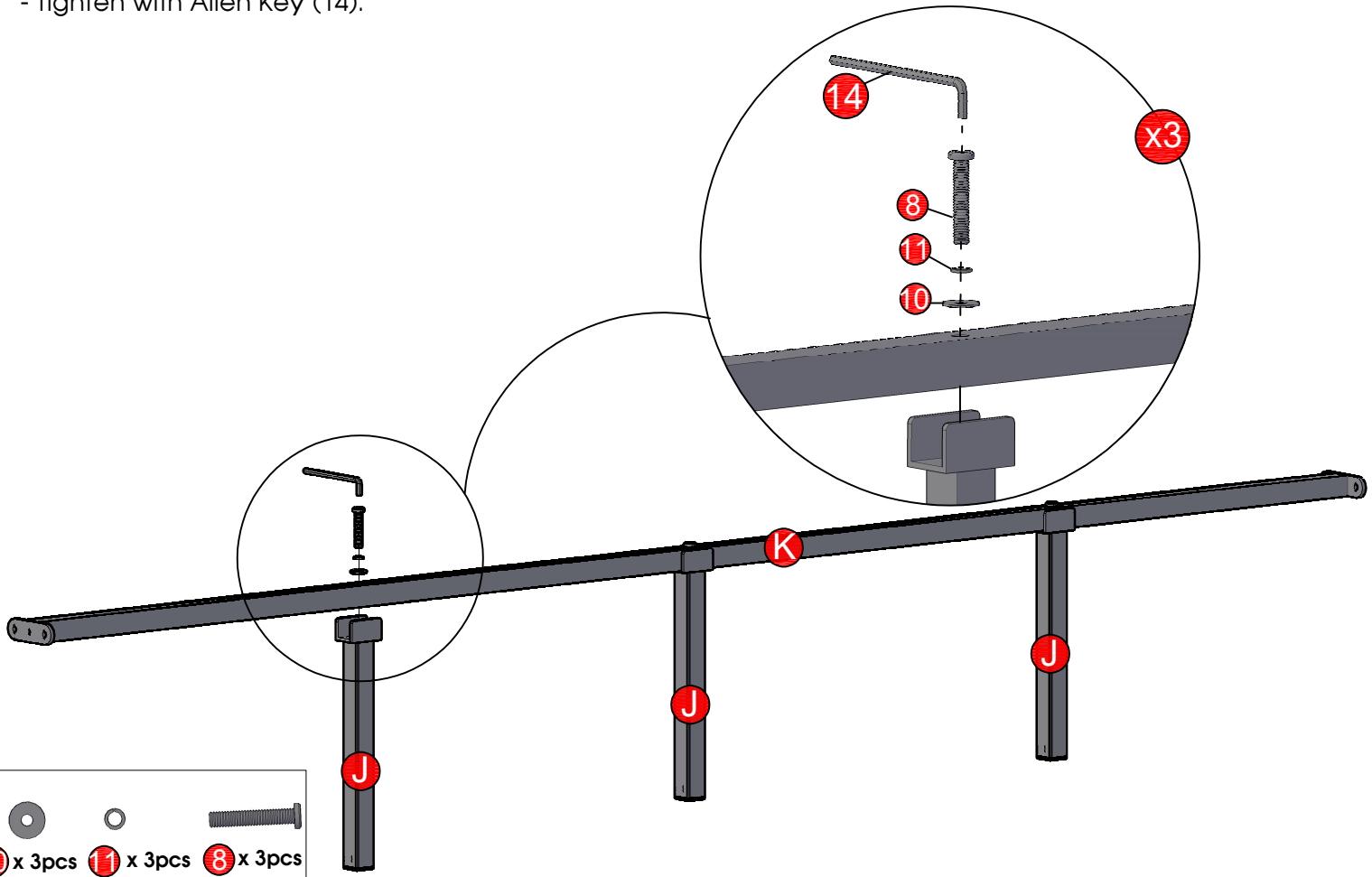

STEP 6

- Attach Centre rail (From step 5) to the Headboard and Footboard using Bolts (7), Flat washers (10) and Lock washers (11).
- Tighten with Allen Key (14).

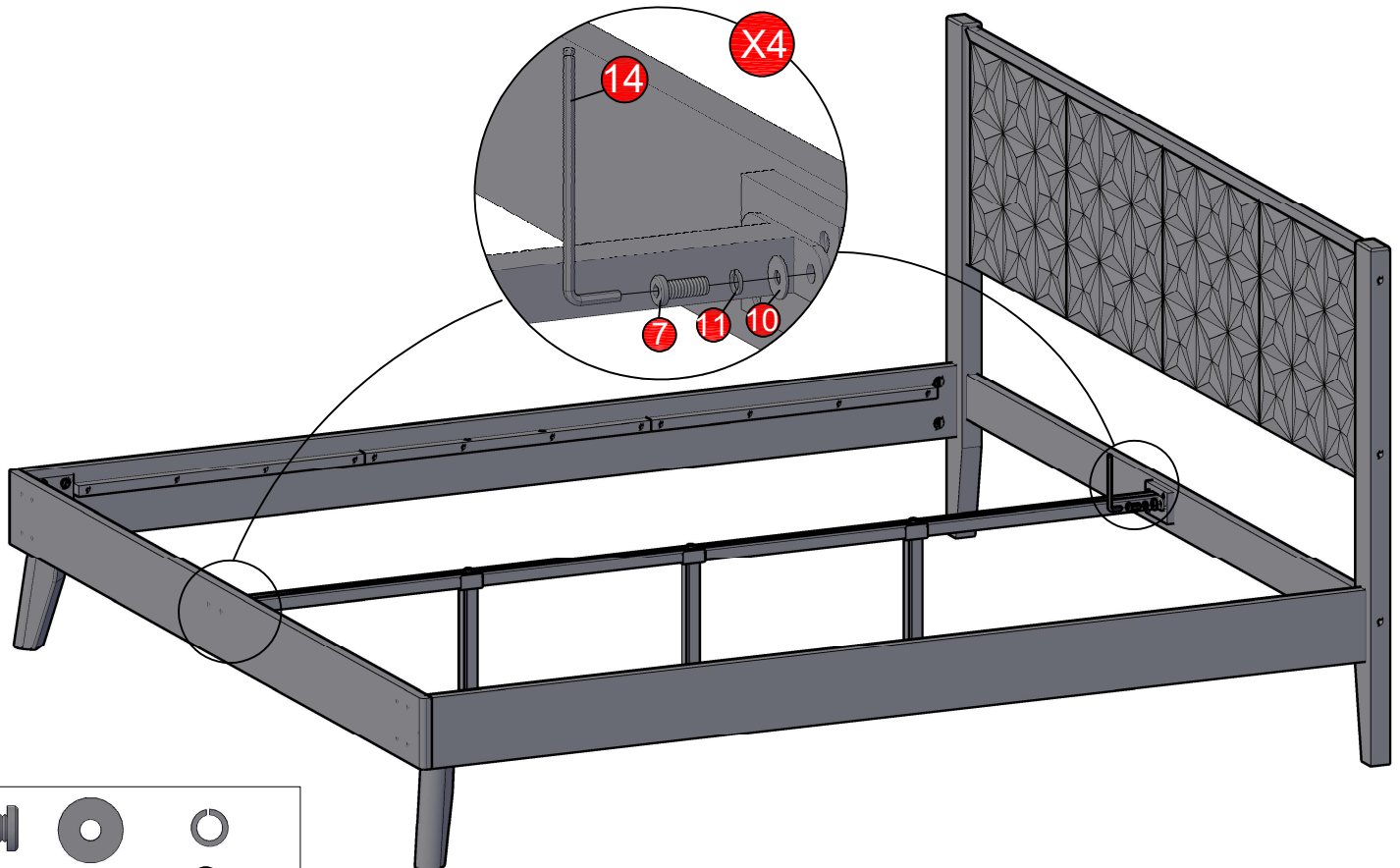

STEP 7

- Attach Wooden cap (13) to the Headboard.
- Secure Slats (1) on bed frame with Screws (12), and complete the assembly.

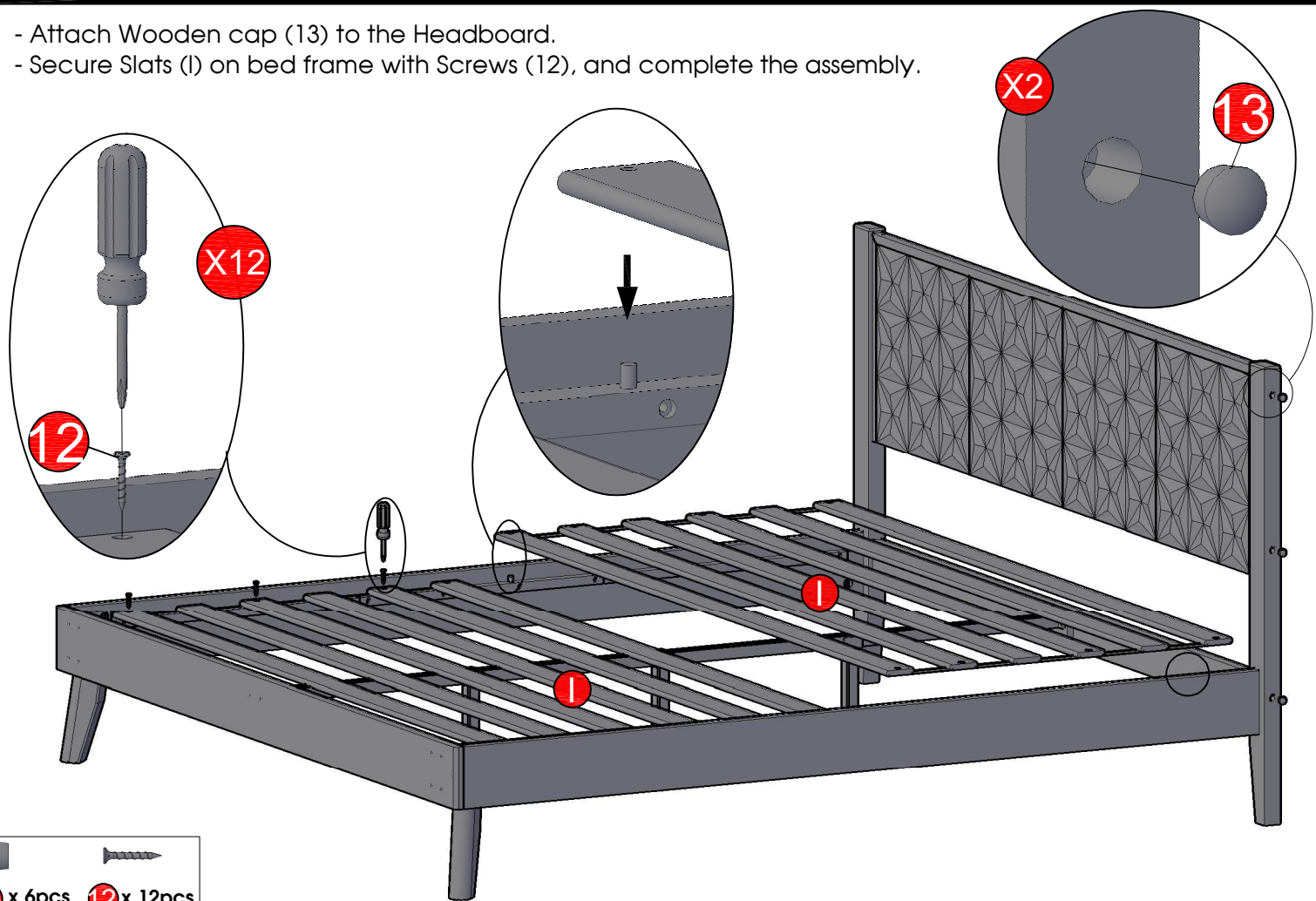

ASSEMBLY IS COMPLETE

