

ASSEMBLY INSTRUCTIONS

SKU:WCK



Description : WICHITA KING BED
Product Dimension : 79.7"Wx85.4"Lx45.3"H
Cube Size : 84.5"x21.2"x6"

NW: 95.7 LBS
GW: 104.5 LBS

BEFORE ASSEMBLY





Thank you for purchasing this quality product. This product has been designed for easy assembly and constructed for durability. Please take the time to read and follow the assembly instructions carefully.

Be sure to check all packing material carefully for small parts which may have come loose inside the carton during shipment. Please separate, identify, and count all parts and metal hardware. Compare with part list to be sure all parts are present.

If hardware is missing or you have difficulty assembling this product, please call for us.

IMPORTANT NOTE:

- Place all wooden parts on a clean and smooth surface such as a rug or carpet to avoid the parts from being scratched.
- Remove all wrapping material, including staples & packing straps before you start to assemble.
- DO NOT tighten all screws and bolts until completely assembled.
- Keep all hardware parts out of reach of children.

Estimated time for assembly	People recommended for assembly	Tools Needed	Use power tools with caution
 - Allow 60 minutes.	 2 People Build - Make it a team effort! Grab a friend for quicker, easier assembly.	 - Grab a Phillips head screwdriver to conquer this assembly.	 -Use power tools with caution

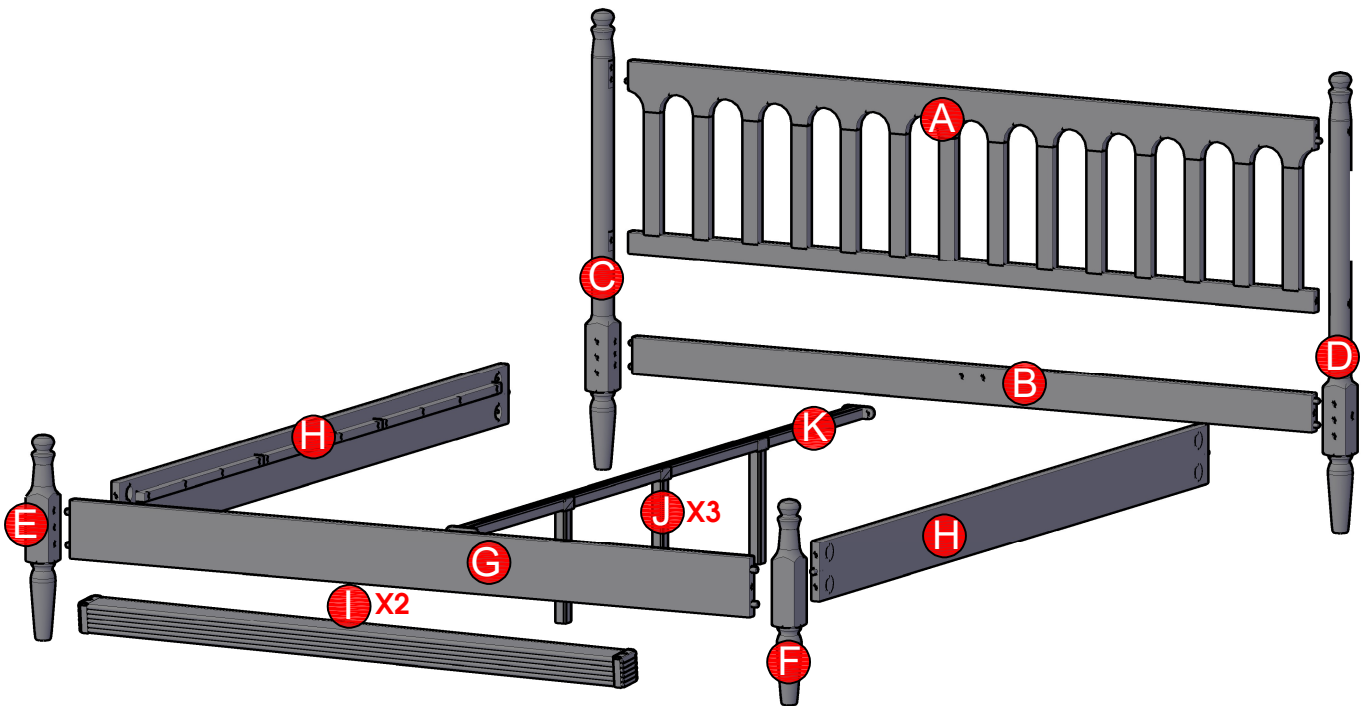

PART LIST

- When unpacking, please be careful not to discard any parts with the packaging. Before continuing, please make sure you have the following parts.

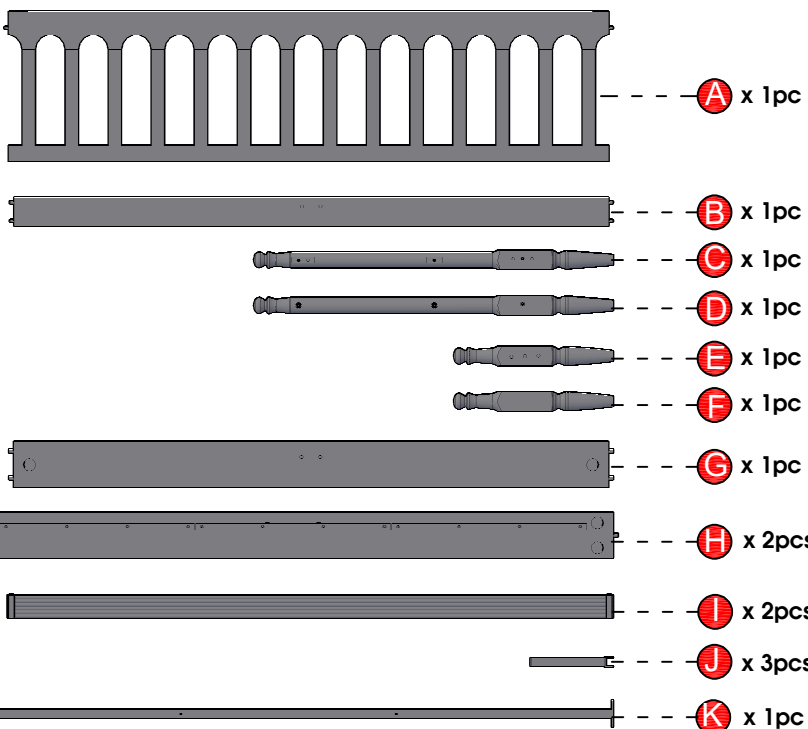

HARDWARE LIST

When unpacking, please be careful not to discard any parts with the packaging. Before continuing, please make sure you have all of the following hardware:

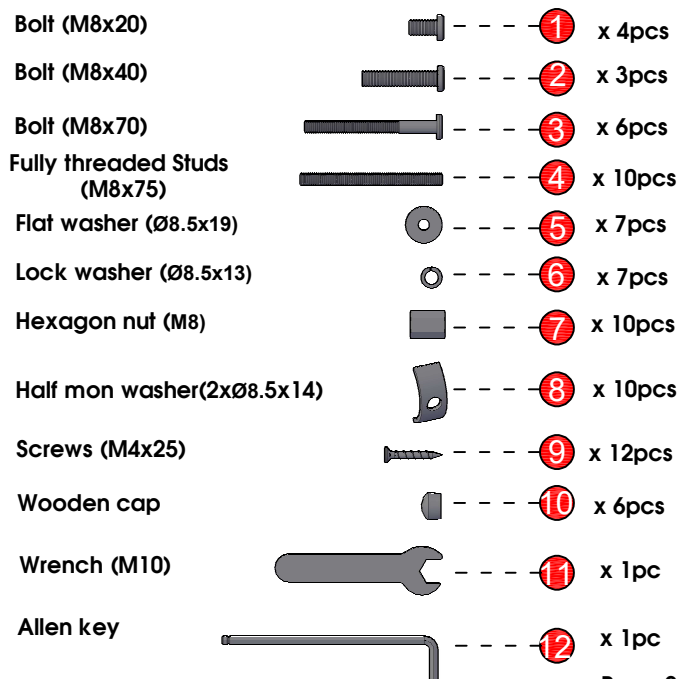

STEP 1

- Attach the Headboard legs (C)&(D) to the Headboard panel (A) and Headboard stretcher (B) by using bolts (3).
- Tighten with Allen key (12) as shown below.

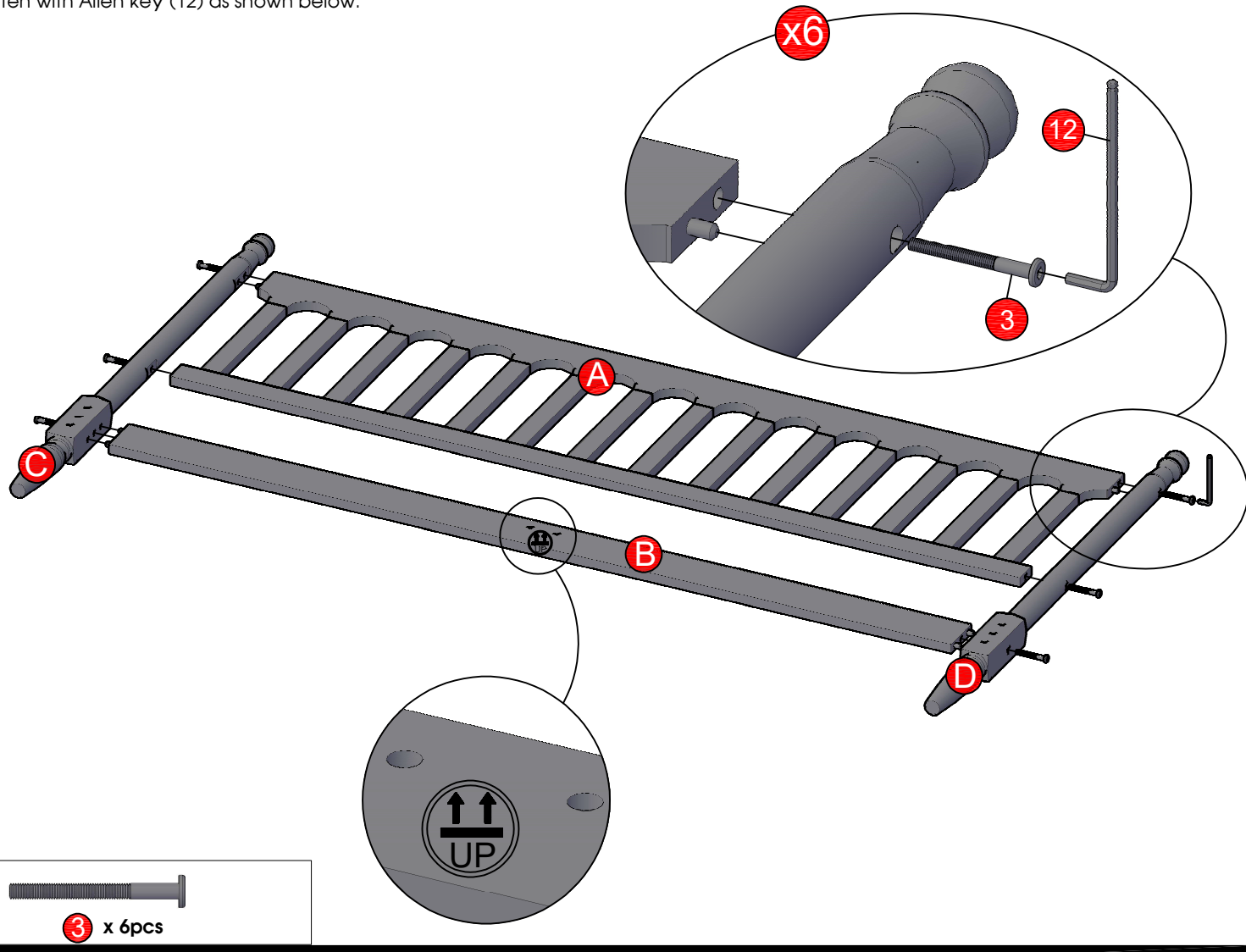

STEP 2

- Attach fully threaded Studs (4) to the Footboard legs (E)&(F).
- Attach Footboard panel (G) to the Footboard (E)&(F) by using Hexagon nut (7), Half Moon washer (8).
- Tighten with Wrench (11) as shown below.

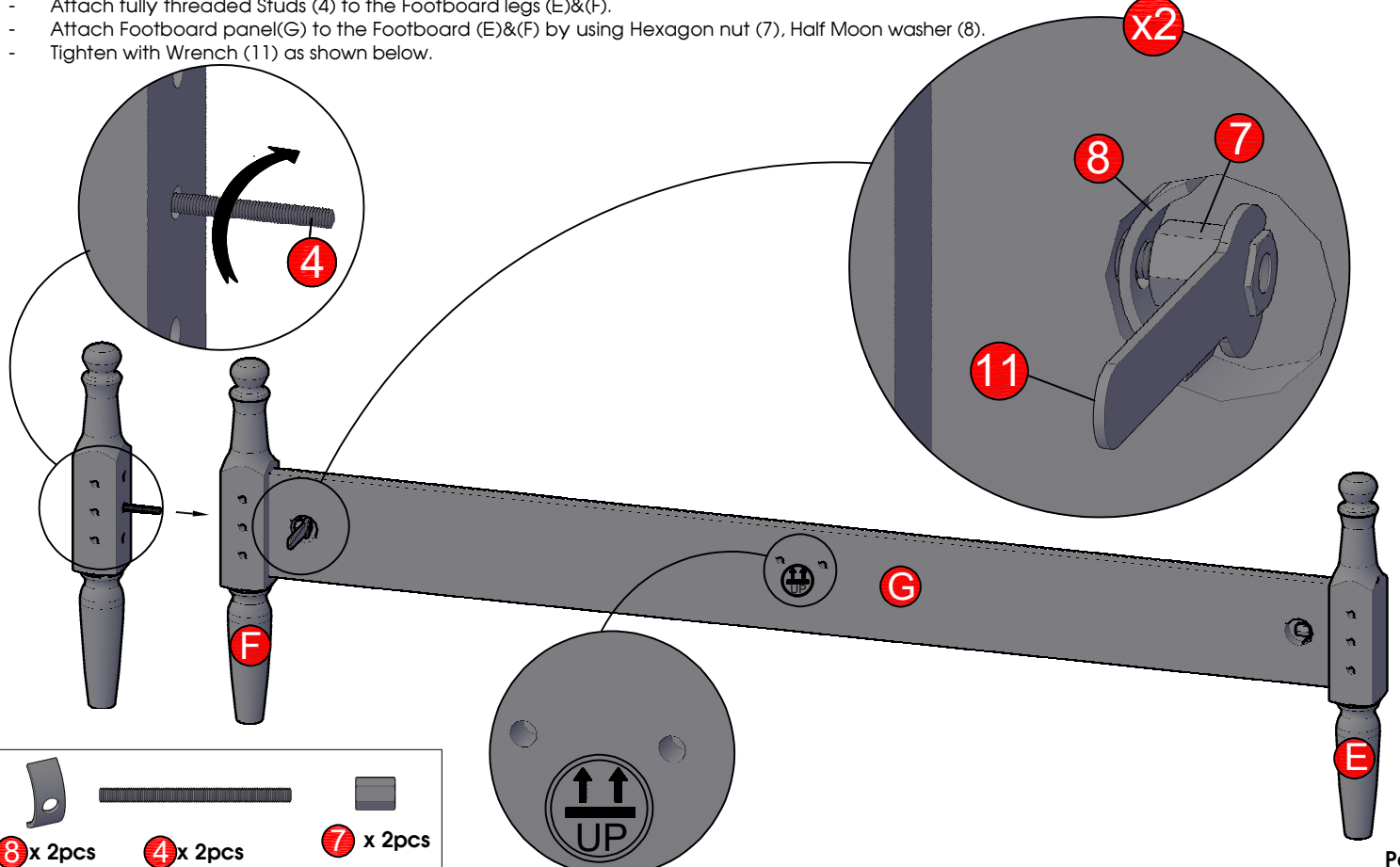

STEP 3

- Attach fully threaded Studs (4) to the Headboard legs on the step 1.

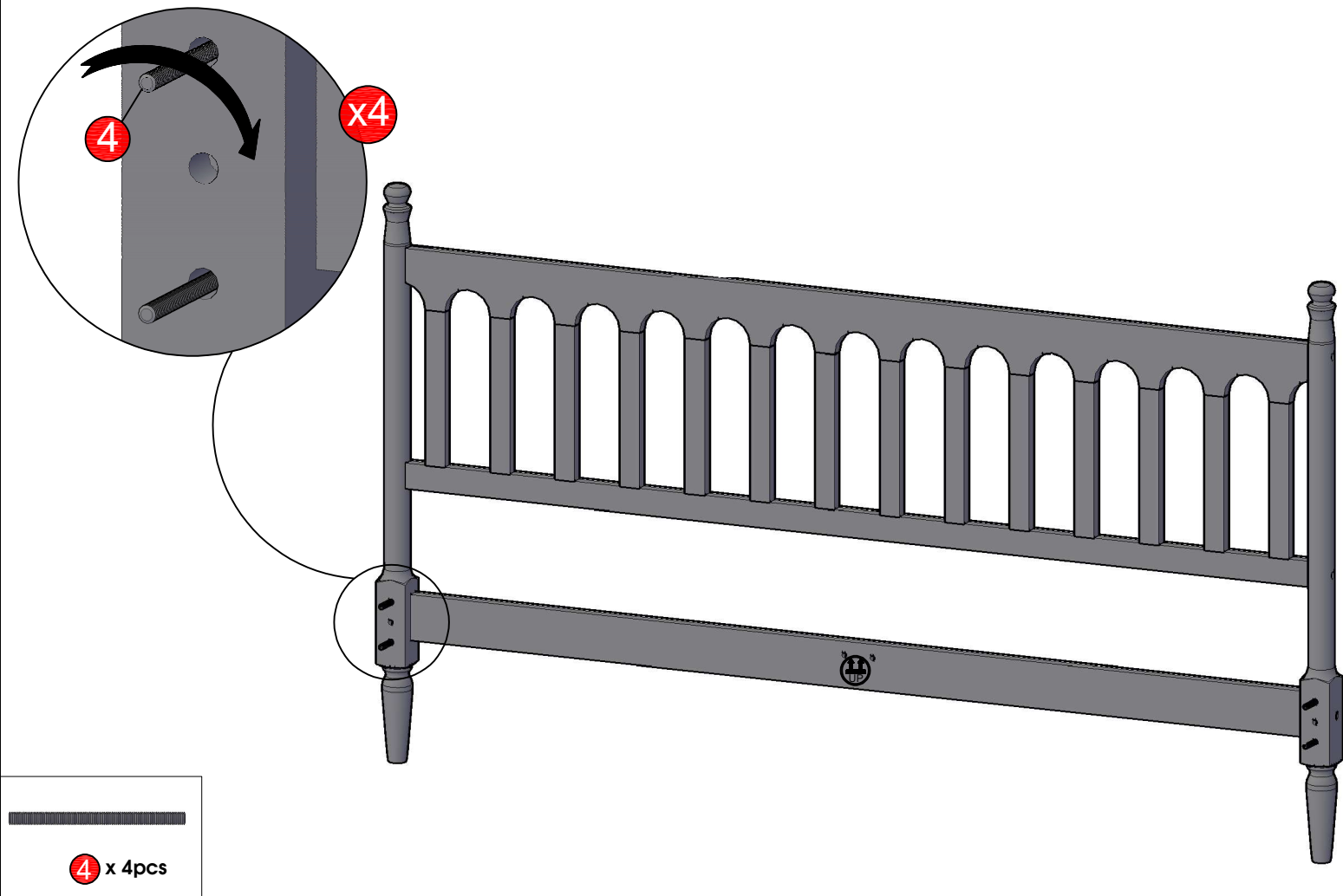

STEP 4

- Attach fully threaded Studs (4) to the Footboard legs on the step 2.

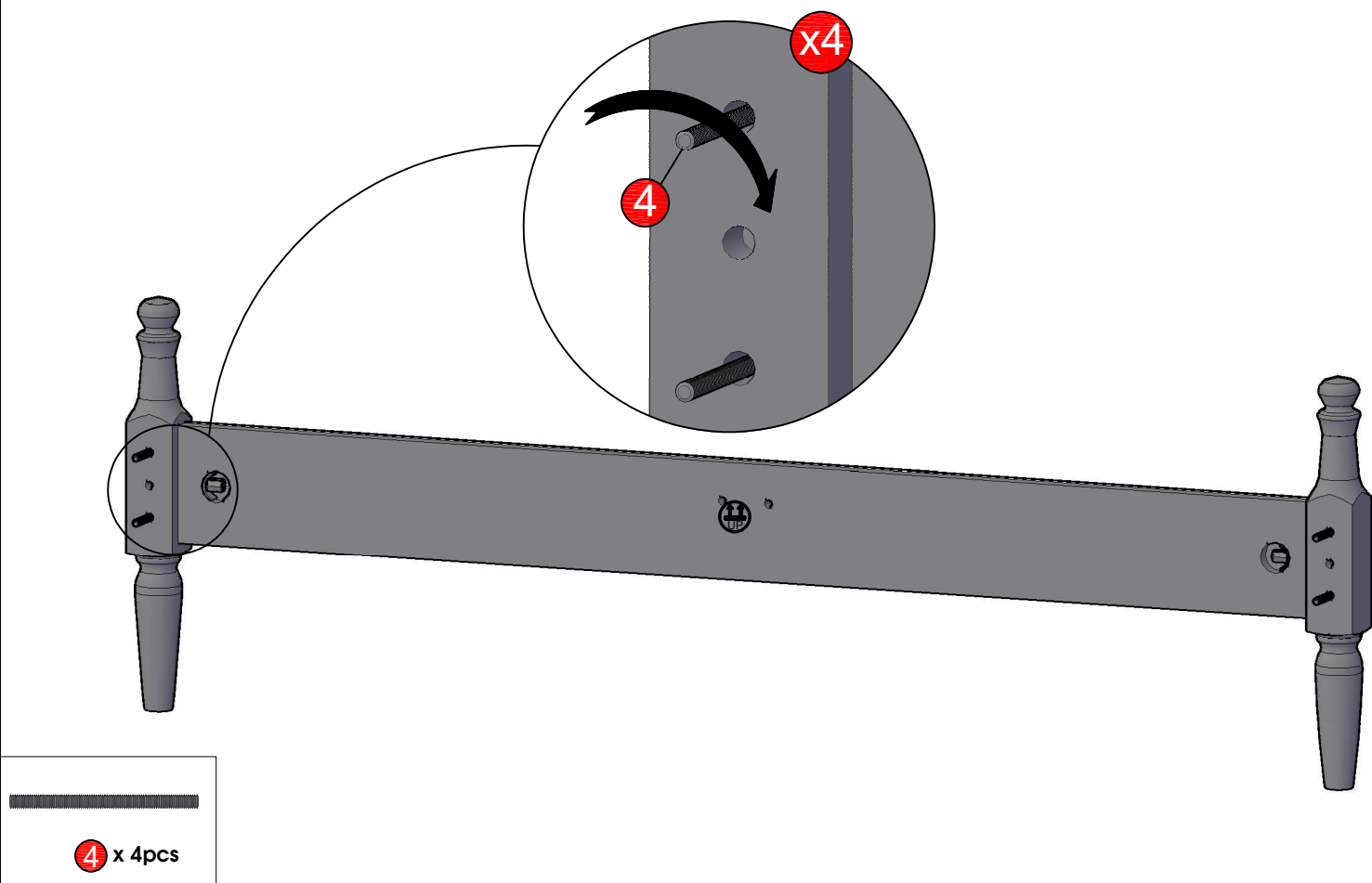

STEP 5

- Find some yoga blocks, books, or anything you have near you to prop up the Side Rails (H) while attaching them to the Headboard.
- Attach Side rails (H) to the Headboard leg (on the step 3) by using Hexagon nut (7), Half Moon washer (8).
- Tighten with Wrench (11) as shown below.

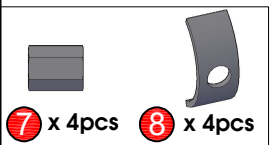
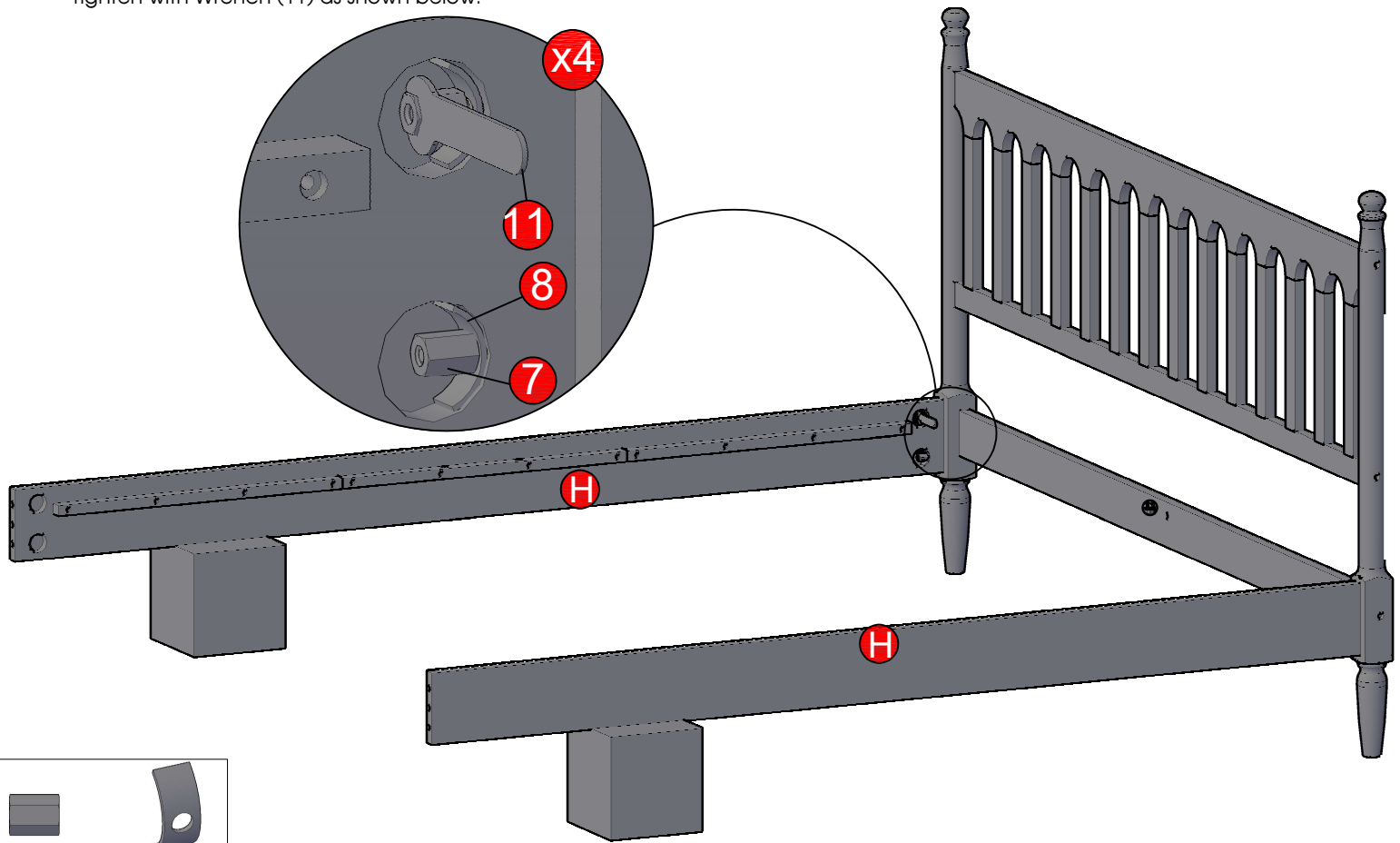

STEP 6

- Attach Side rails to the Footboard leg by using Hexagon nut (7), Half Moon washer (8).
- Tighten with Wrench (11) as shown below.

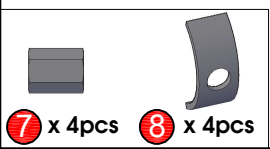
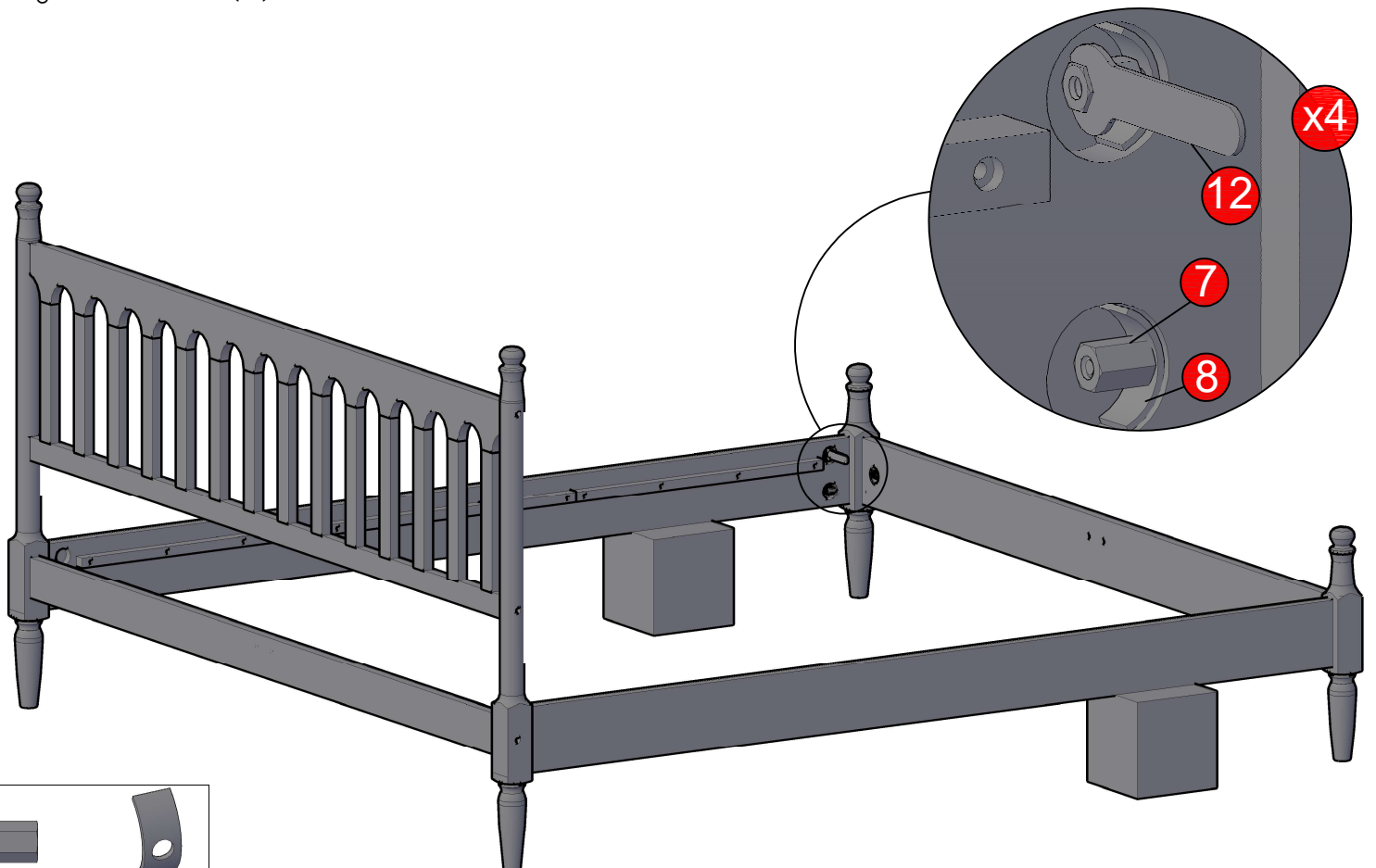

STEP 7

- Attach Support legs (J) to Centre rail (K) secure using Bolts (2), Flat Washers (5) and Lock Washers (6).
- Tighten with Allen Key (12).

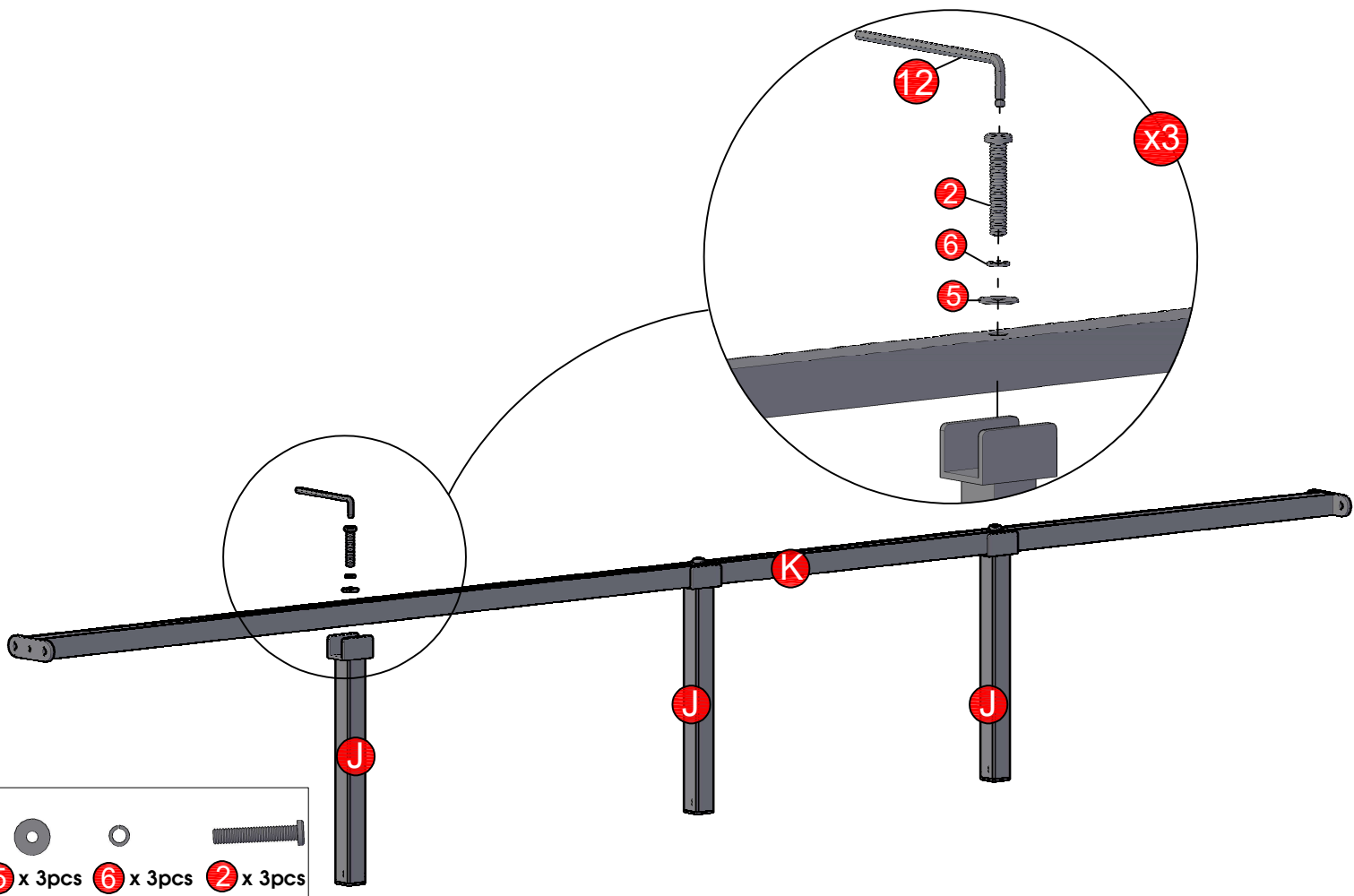

STEP 8

- Attach Centre rail (on step 7) to Headboard and Footboard using bolts (1), Flat Washers (5) and Lock Washers (6).
- Tighten with Allen Key (12) as shown below.

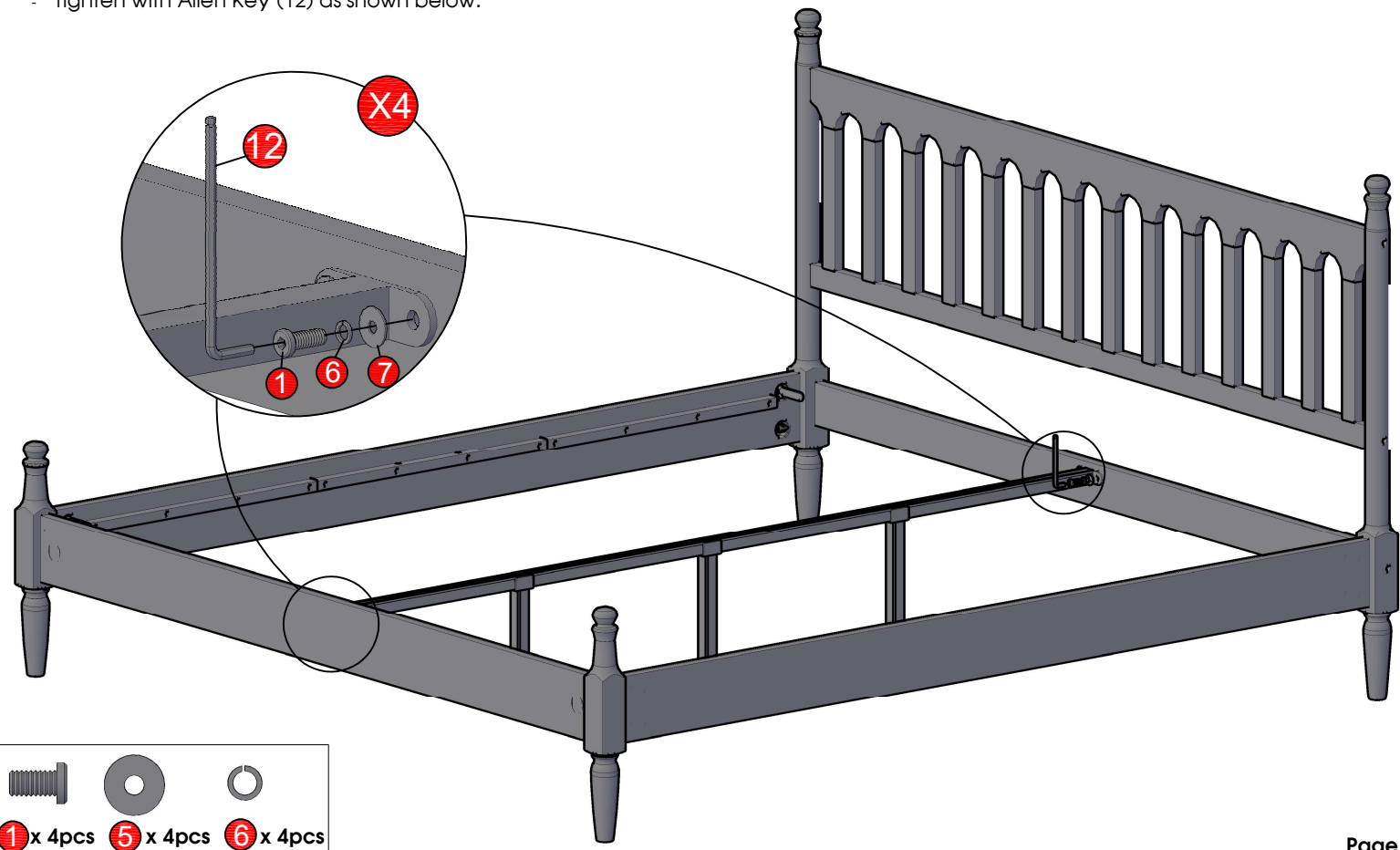

STEP 9

- Attach Wooden cap (10) to Headboard as shown below.
- Place the Slats (1) on the bed frames use the screw driver to tighten the screws (9) as shown below, and complete the assembly.

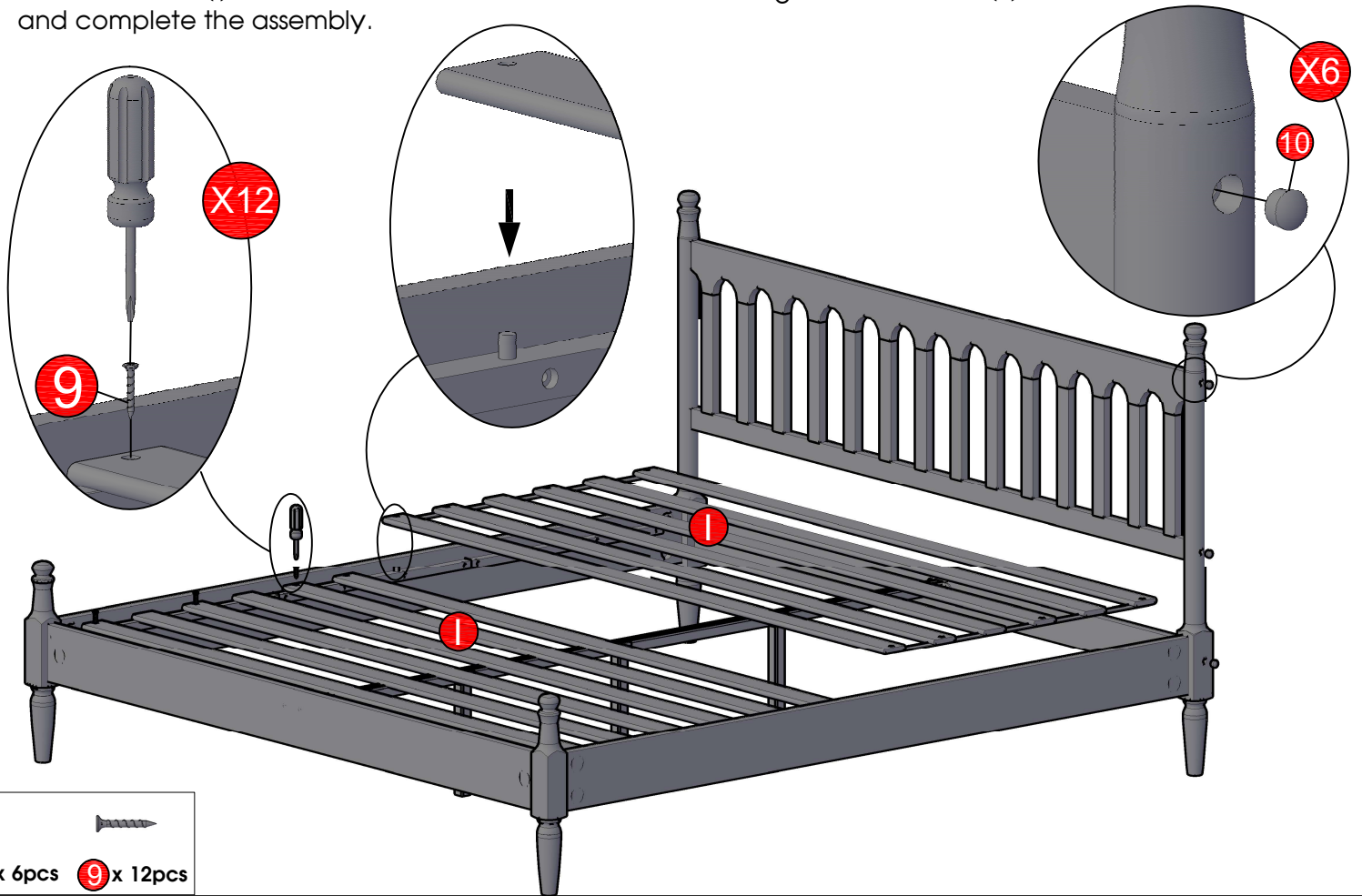

ASSEMBLY IS COMPLETE

